

ITEM	QTY	PARTS LIST	
		PART NUMBER	DESCRIPTION
1	6	TOP CHORD RHS 80X66	
2	6	B_CHORD_01	
3	6	POST 00 - SHS 50X2	J7535-P0
4	4	BRACING_SHS50X2_1275F	
5	4	BRACING_SHS50X2_480B	
6	40	BRACING_PLATE_TYPE02	
7	96	WASHER_18X4	
8	4	BRACING_SHS50X2_1275B	
9	4	BRACING_SHS50X2_2475B	
10	4	BRACING_SHS50X2_2475F	
11	6	VERTICAL_POST_01	
12	6	VERTICAL_POST_B01	
13	6	VERTICAL_POST_B02	
14	6	VERTICAL_POST_B03	
15	4	BRACING_SHS50X2	
16	6	VERTICAL_POST_01_480	
17	6	VERTICAL_POST_B00	
18	6	INCLINED_POST_BC01	
19	6	INCLINED_POST_BC02	
20	6	INCLINED_POST_BC03	
21	6	VERTICAL_POST_B04	
22	6	INTERNAL_EXTRUSION_WEB_02	
23	6	INTERNAL_EXTRUSION_WEB_01	
24	6	INCLINED_POST_FR03	
25	1	TRUSS_LAYOUT_S01	
26	32	POST_PLATE_S01	
27	12	POST_A_BC00	

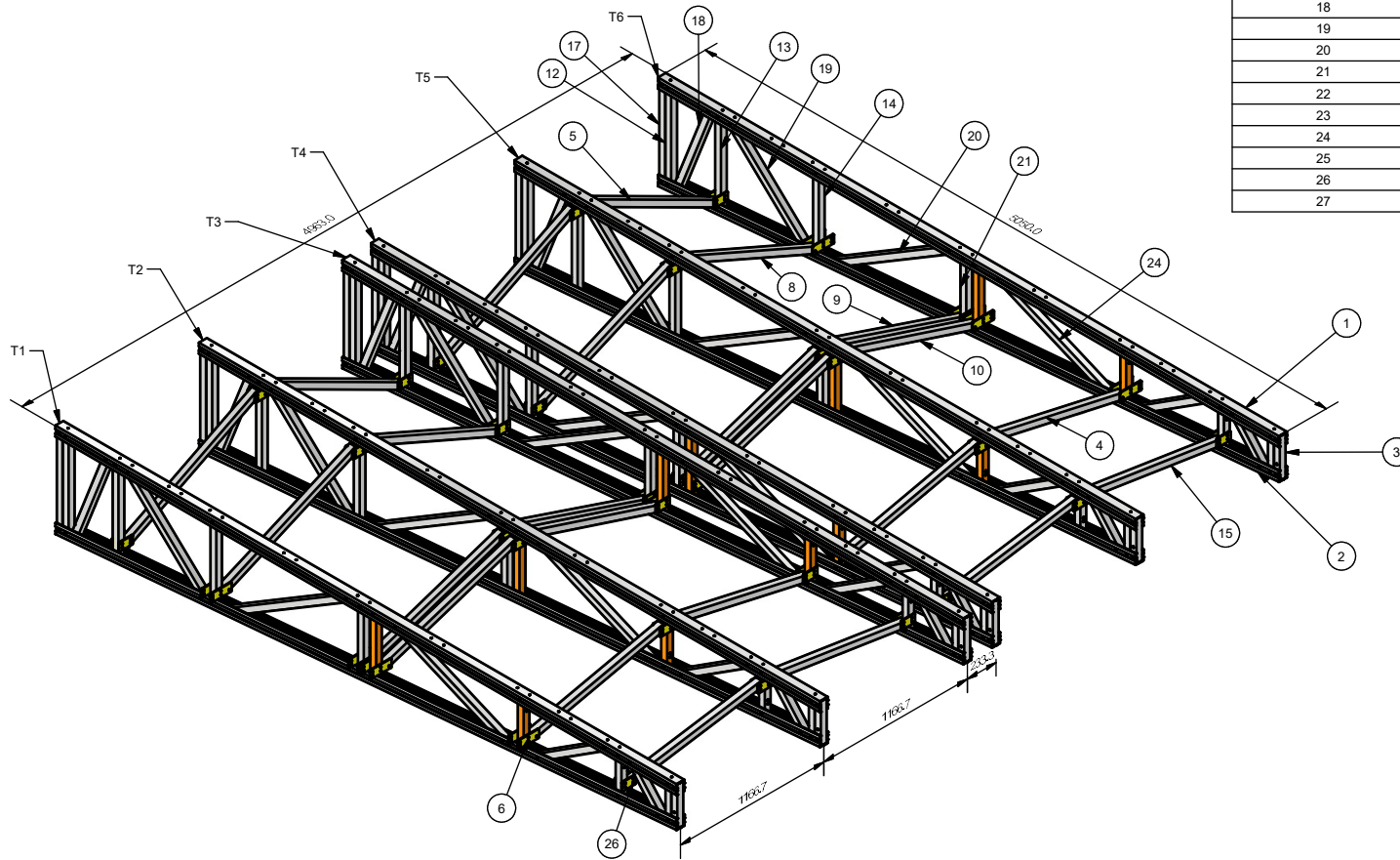

ISOMETRIC VIEW
SCALE: 1 : 30

HART SAFETY QC CHECK	DATE	CHECKED BY
FABRICATED		
ASSEMBLED		
VISUAL QC CHECK		

ISSUE FOR REVIEW

REV	DESCRIPTION	DATE	NOTES: 1. ALL DIMENSIONS ARE IN mm UNO. 2. TOLERANCES: GENERAL: +/-0.50mm ANGLE: +/-0.50°	Hart X	JOB NAME:	TITLE:	DATE: 05/03/2026
1					J7535		DRAWN: HART AUSTRALIA
2							
ASSEMBLY NAME: ROOF MOUNTED			SHEET NO 1/3	SCALE: AS SHOWN	WEIGHT: 224.06 kg	QTY	PROJECT NO: P3150
				JOB NO: J7535	DRAWING VERSION: SITE ASSEMBLY	DRAWING NO: J7535-0000-003	REVISION V1.2

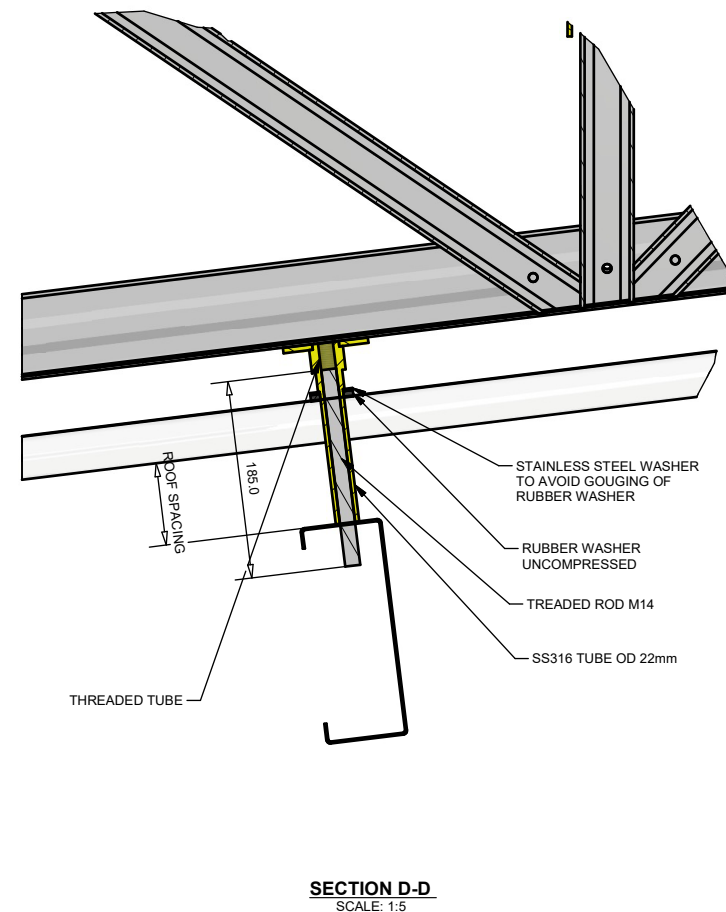
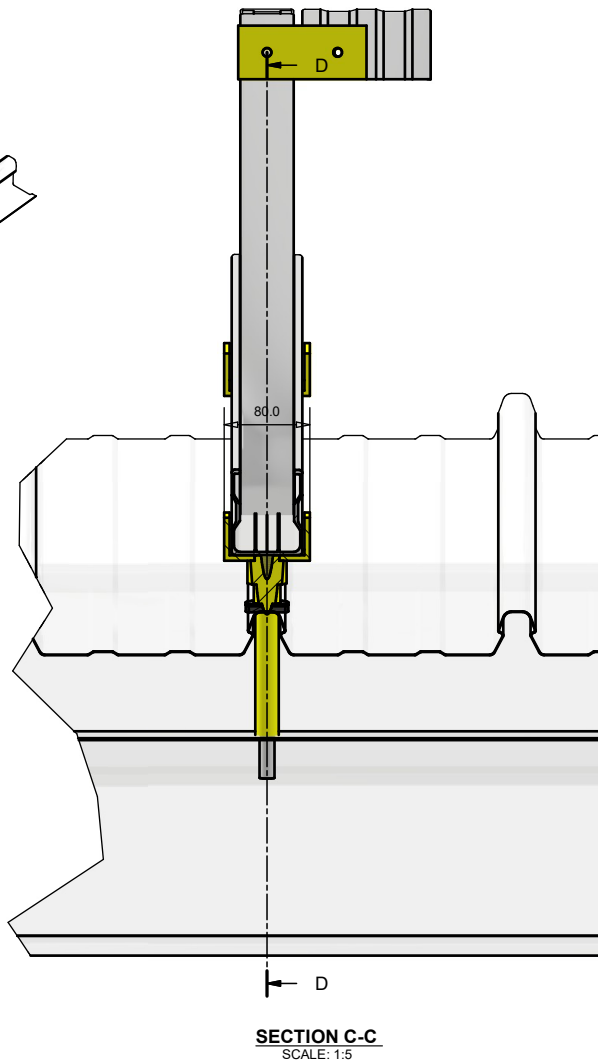
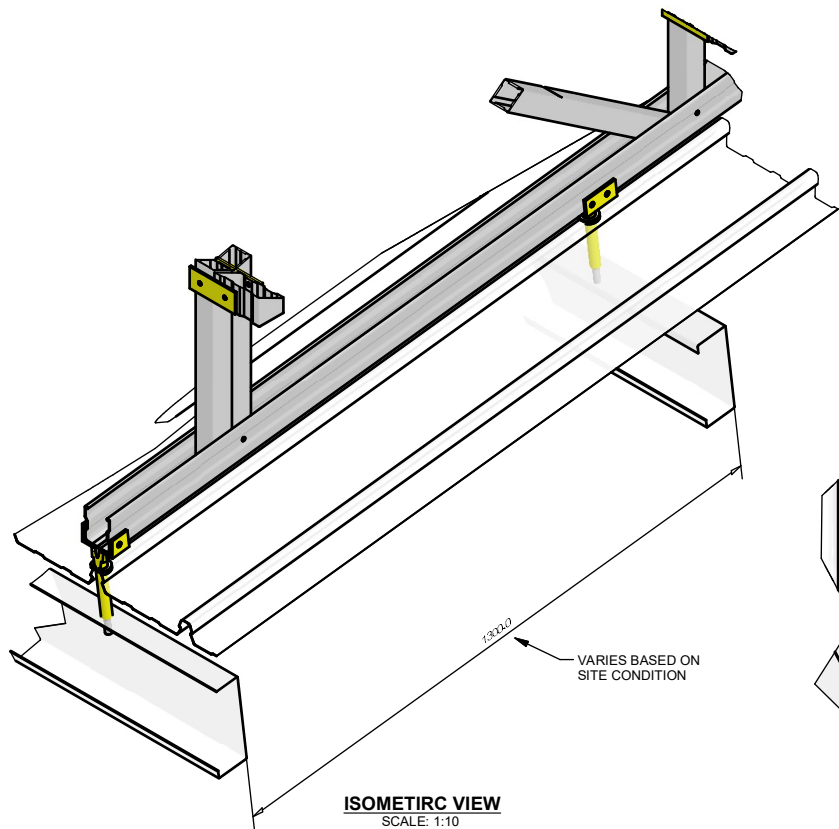

ISSUE FOR REVIEW

HART SAFETY QC CHECK	DATE	CHECKED BY
FABRICATED		
ASSEMBLED		
VISUAL QC CHECK		

REV	DESCRIPTION	DATE	NOTES: 1. ALL DIMENSIONS ARE IN mm UNO. 2. TOLERANCES: GENERAL: +/-0.50mm ANGLE: +/-0.50°	Hart X	JOB NAME:	TITLE:	DATE:
1					J7535	ROOF MOUNTED PLATFORM	18/02/2026
2							DRAWN: HART AUSTRALIA
	ASSEMBLY NAME: ROOF MOUNTED	SHEET NO 1/1	SCALE: AS SHOWN	WEIGHT: 2974.28 kg	QTY	DRAWING VERSION: SITE ASSEMBLY	REVISION V1.2
					J7535	DRAWING NO: J7535-0000-001	PROJECT NO: P3150